

BAKING METER

BC-10

INSTRUCTION MANUAL

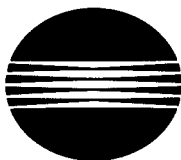

KONICA MINOLTA

Safety Symbols

The following symbols are used in this manual to prevent accidents which may occur as result of incorrect use of the instrument.



Denotes a sentence regarding safety warning or note.
Read the sentence carefully to ensure safe and correct use.



Denotes a prohibited operation.
The operation must never been performed.



Denotes an instruction.
The instruction must be strictly adhered to.



Denotes an instruction.
Disconnect the AC power cord from the AC outlet.



Denotes a prohibited operation.
Never disassemble the instrument.

⚠ SAFETY PRECAUTIONS

- To ensure correct use of this Baking Meter BC-10, read the following points carefully and adhere to them. After you have read this manual, keep it in a safe place where it can be referred to anytime a question arises.

⚠ WARNING (Failure to adhere to the following points may result in death or serious injury)	
<p> Do not use the Baking Meter in places where flammable or combustible gases (gasoline etc.) are present. Doing so may cause a fire.</p>	<p> The Baking Meter should not be operated if it is damaged, or smoke or odd smells occur. Doing so may result in a fire. In such situations, turn the power OFF immediately disconnect the AC adapter from the AC outlet, and contact the nearest authorized service facility.</p>
<p> When using an AC adapter, use the AC adapter supplied as an optional AC adapter AC-A12 with the Baking Meter, and connect it to an AC outlet (100 to 240Vac, 50/60 Hz). Failure to do so may damage the AC adapter, causing a fire or electric shock.</p>	
<p> If the Baking Meter will not be used for a long time, disconnect the AC adapter from the AC outlet. Accumulated dirt or water on the prongs of the AC adapter's plug may cause a fire and should be removed.</p>	<p> Do not disassemble or modify the Baking Meter. Doing so may cause a fire or electric shock.</p>
<p> Do not insert or disconnect the AC adapter with wet hands. Doing so may cause electric shock.</p>	<p> Take special care not to allow liquid or metal objects to enter the Baking Meter. Doing so may cause a fire or electric shock. Should liquid or metal objects enter the Baking Meter, turn the power OFF immediately disconnect the AC adapter from the AC outlet, and contact the nearest Minolta authorized service facility.</p>
<p> Do not disassemble or modify the AC adapter. Doing so may cause a fire or electric shock.</p>	
	<p> Do not dispose of batteries in fire, short their terminals, apply heat to them, or disassemble them. Also, do not recharge them. Doing so may cause explosion or heat generation, resulting in fire or injury</p>

⚠ CAUTION (Failing to adhere to the following points may result in injury or damage to the Baking Meter or other property.)	
<p> Do not perform measurement with the measurement aperture directed towards your face. Doing so may cause damage to your eyes.</p>	<p> Do not use batteries other than those specified. Also, do not mix new and old batteries, or mix batteries of different types. When installing batteries in the instrument, make sure that they are correctly oriented according to the (+) and (-) marks. Failure to adhere to these instructions may cause explosion of the batteries or leakage of electrolyte, resulting in fire, injury or air pollution.</p>
<p> Do not place the Baking Meter on an unstable or sloping surface. Doing so may result in its dropping or overturning, causing injury. Take care not to drop the Baking Meter when carrying it.</p>	

The Baking Meter BC-10 is an extremely compact, extremely easy-to-use tristimulus colorimeter specifically designed for measuring color in BCU (Baking Contrast Units). After switching on the Baking Meter and performing white calibration by placing the tip of the Baking Meter against the included white tile and pressing the measuring button, measurements can be taken by simply positioning the Baking Meter on the specimen and pressing the measuring button. The Baking Meter can be easily operated with one hand and is battery powered for complete portability.

Please read and study this manual before using the Baking Meter for the first time and keep this manual handy for future reference.

CONTENTS

TAKING MEASUREMENTS IMMEDIATELY	3
NAMES OF PARTS	4
FUNCTIONS OF CONTROLS	5
POWER.....	6
Installing Batteries	6
Using AC Adapter	7
DISPLAYS	8
Calibration Display	8
Measurement Display	8
Display with "Memory Full" Message	8
Display with "Printing" Message.....	8
Scroll Display	8
WHITE CALIBRATION	9
TAKING MEASUREMENTS	10
AVERAGE (STATISTICAL CALCULATION) MEASUREMENT.....	11
CALCULATION METHODS	12
ERROR MESSAGES	13
CAUTION	14
CARE AND STORAGE	14
ACCESSORIES	15
Standard Accessories	15
Optional Accessories	15
SPECIFICATIONS	16

TAKING MEASUREMENTS IMMEDIATELY

To measure the color of a specimen, follow the steps below.

- For more information, refer to the corresponding section of this manual.

1 Install four AA-size batteries.

- Check that the polarities are as shown in the battery chamber.

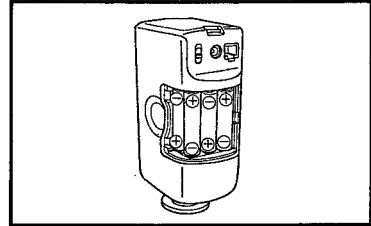

2 Switch on the instrument. The display will automatically change to the calibration display.

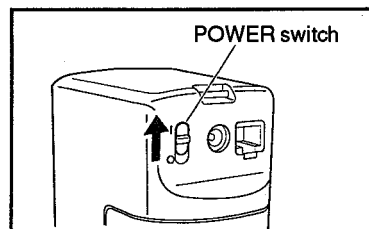

3 Place the tip of the Baking Meter flat against the white calibration plate and press the measuring button to perform white calibration.

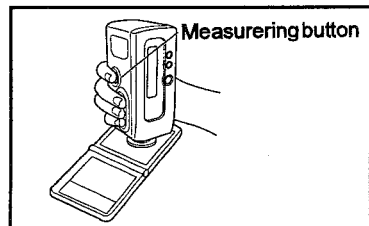

4 Place the tip of the Baking Meter flat against the specimen to be measured and press the measuring button. The specimen will be measured and the measurement results will be shown in the display.

- Do not apply excessive pressure against the specimen if it is made of a soft material.
- Press BCU/Lab key to choose the desired display unit.

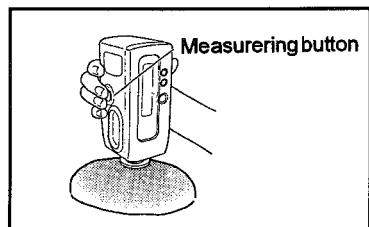

NAMES OF PARTS

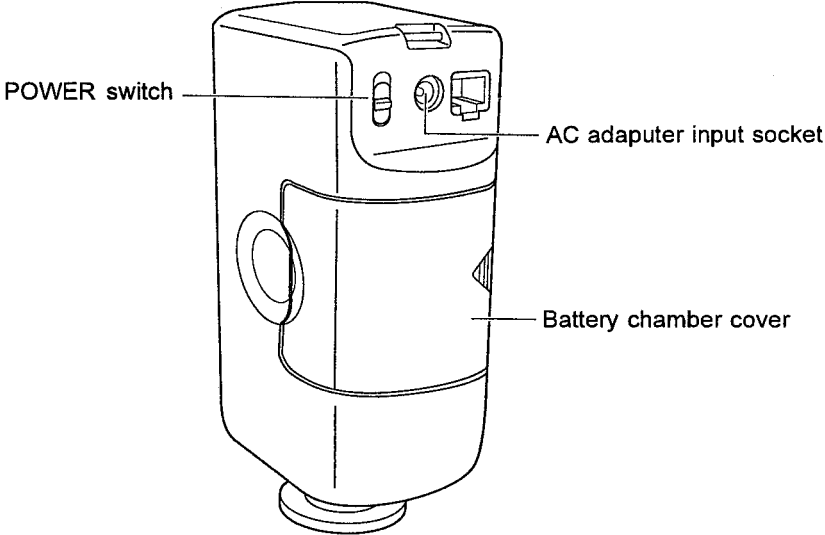
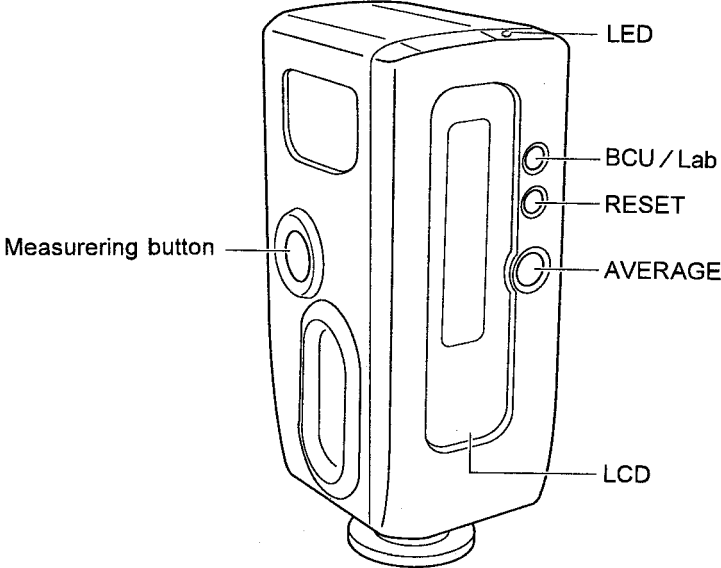

FUNCTIONS OF CONTROLS

Measuring button	Takes measurement.
AVERAGE	Enters and changes statistical calculation mode.
RESET	Deletes all measurement data in memory to start average measurements.
BCU/Lab	Changes display unit between BCU or L*a*b*.
LED	Lit while a measurement is taken.
LCD	Displays measurement results, etc.
POWER switch	Switches power on (I) and off (O). When the power switch is turned off, all data stored in the memory of the BC-10 will be deleted.
Battery chamber cover	Covers battery chamber which holds four AA-size batteries.
AC adapter input socket	Used for connecting optional AC adapter to supply power from an AC socket. Use only AC adapter AC-A12.

POWER

The Baking Meter can be powered by either four AA-size batteries or optional AC Adapter AC-A12.

Installing Batteries

- When installing or removing batteries, be sure the POWER switch of Baking Meter is set to O (off).
- Do not mix battery types or ages. Mixing battery types or ages could result in battery leakage, reduced battery life, or damage to the Baking Meter.
- Do not touch or short the battery terminals inside the battery chamber. Doing so may damage the Baking Meter.
- Use alkaline-manganese batteries.

- 1 Check that the POWER switch is set to O (off) and slide the battery chamber cover in the direction of the arrow while gently pressing it in.

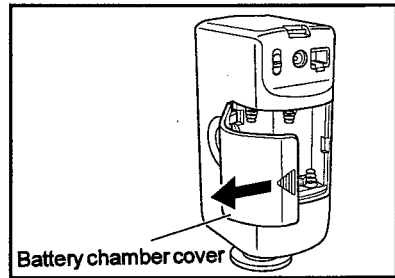

- 2 Install four AA-size batteries in the battery chamber with the polarities as shown inside the chamber.

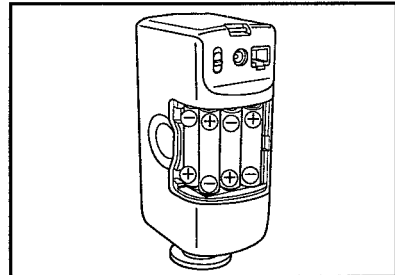

- 3 Close the battery chamber cover.
 - Be sure that both tabs on the battery chamber cover catch.

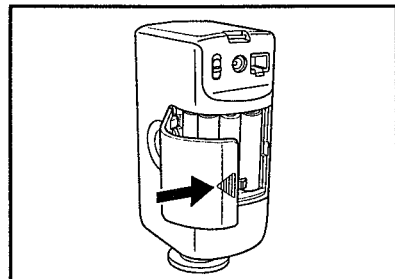

Using AC Adapter

- Use only AC Adapter AC-A12 (available as an optional accessory). Use of other AC adapters may damage the Baking Meter or that of AC adapters.
- When connecting or disconnecting the AC adapter, be sure that the POWER switch of the Baking Meter is set to O (off).

- 1 Check that the POWER switch of the Baking Meter is set to O (off) and insert the output plug of the AC adapter into the AC adapter input socket of the Baking Meter.

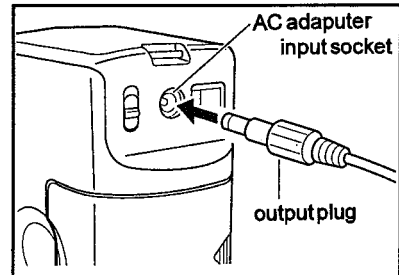

- 2 Insert the input plug of the AC adapter into an AC wall outlet.

DISPLAYS

Calibration Display

```
Set Cal. Plate  
--> Measure
```

Calibration can be performed in this display. This display automatically appears when the Baking Meter is first switched on.

Measurement Display

```
Data 6 BCU 2.76
```

When this display is shown, the Baking Meter is ready to take a measurement.

Statistical Calculation Display

BCU statistics display

```
BCU 7 Ave3.05  
Max3.38 Min2.59
```

White calibration

After the POWER switch is set to | (on), white calibration must be performed before measurements can be taken. White calibration can be performed only when the calibration display is shown; this display appears automatically after the POWER switch is set to | (on).

- 1 Set POWER switch to | (on). The calibration display will appear.

Set Cal. Plate
--> Measure

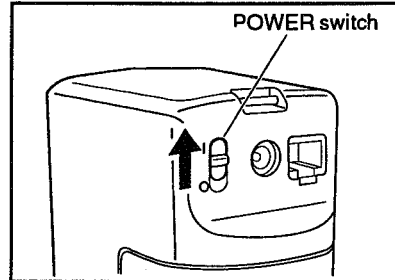

- 2 Place the tip of the Baking Meter flat against the white calibration plate.
 - Use only the white calibration plate having the same serial number as the Baking Meter. Use of a different white calibration plate will result in inaccurate measurements and may also result in error messages.

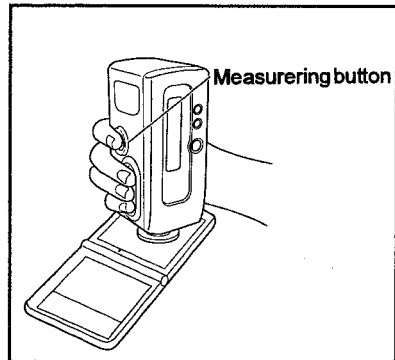

- 3 Press the measuring button. White calibration will be performed and the display will change to the measurement display (showing data if data are stored in memory).

Data	BCU
------	-----

Data	L
a	b

- Press BCU/Lab key to choose the desired display unit.

TAKING MEASUREMENTS

- 1 Set the POWER switch of the Baking Meter to | (on) and perform white calibration (see previous page).

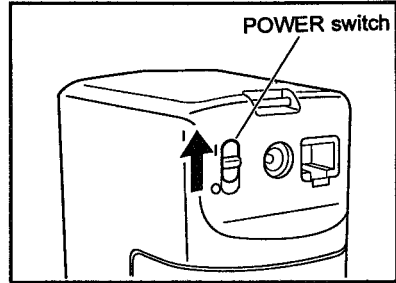

- 2 Place the tip of the Baking Meter flat against the sample to be measured and press the measuring button. When measurement has been completed, a beep will sound and the measurement results will appear in the display. The LED will be lit while the measurement is being taken.

Data 6	BCU 2.76
--------	----------

- If a measurement is taken when the number of measurements stored in memory has already reached 16, new measurement data will replace the oldest data in memory.
- Do not apply excessive pressure to the specimen if it is made of a soft material.
- Press BCU/Lab key to choose the desired display unit.

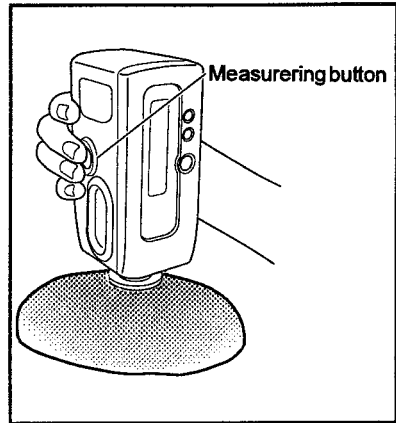

Data 6	L 50.3
a+ 5.4	b+15.7

AVERAGE (STATISTICAL CALCULATION) MEASUREMENT

The Baking Meter BC-10 can perform statistical calculations using data stored in memory and determine the maximum, minimum and mean.

1 Press **Reset** to clear all data stored in the Baking Meter.

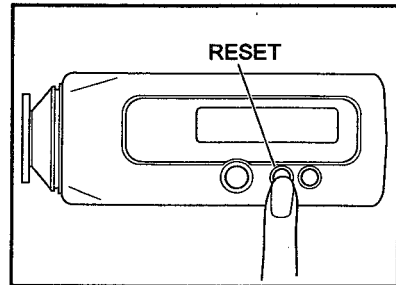

2 Take the desired number of measurements. (The maximum number of measurements which can be taken is 16.)

3 Press **Average** repeatedly to choose the desired statistical data display. Display will change as follows:

- Only data which was stored in the memory will be used for calculations.
- When the power switch is turned off, all data stored in the memory of the Baking Meter will be deleted.
- When the Lab display unit is selected, **Average** value of $L^*a^*b^*$ will be displayed first.

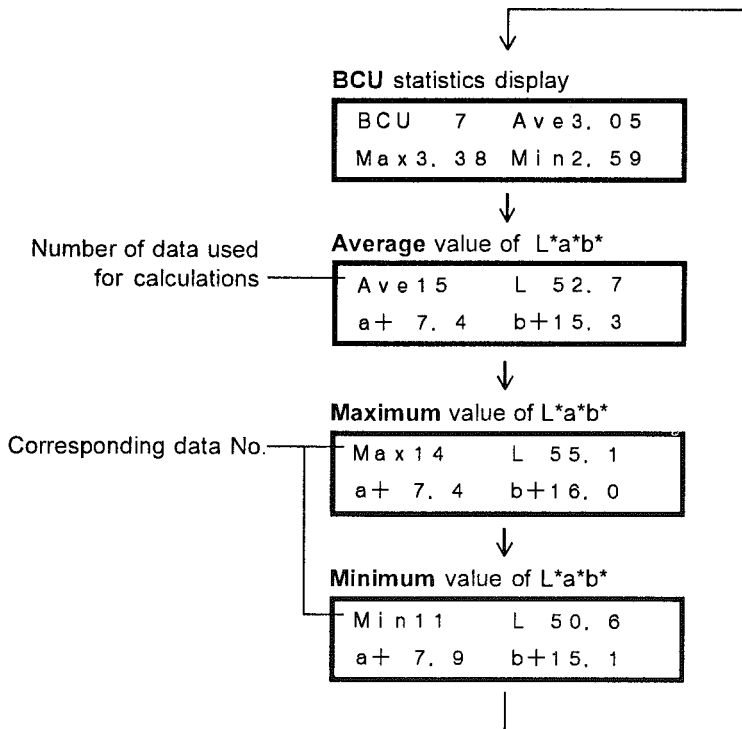
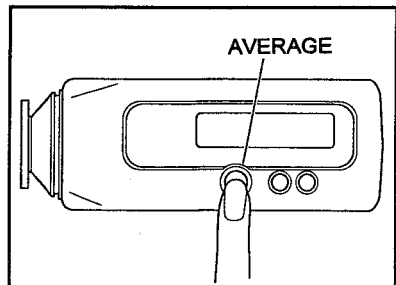

CALCULATION METHODS

BCU (Baking Contrast Units)

- "0" will be displayed when BCU value is less than zero ($BCU \leq 0$).

Average of BCU

The averages of the measured tristimulus values X, Y, and Z of specimens are calculated and the BCU value is calculated from the average Y value.

Average of L*a*b*

The averages of the measured tristimulus values X, Y, and Z of specimens are calculated and the L*a*b* values are calculated from the average tristimulus values.

Maximum or minimum value of L*a*b*

The maximum or minimum of the measured tristimulus value Y is found and the L*a*b* values are calculated using the X, Y, and Z values for the measurement corresponding to the maximum or minimum Y value.

ERROR MESSAGES

- If any of the following messages continue to be displayed after the suggested corrective action has been taken, contact the nearest Minolta authorized service facility.

Error message	Cause	Corrective action
Measure Again	Measurement was not taken correctly (Baking Meter was moved during measurement, ambient light entered measurement aperture, etc.)	Take measurement again, being sure tip of Baking Meter is flat against the specimen and that the Baking Meter is not moved until the beep indicating completion of measurement has sounded. After completion of measurement, the LED also turns off the light.
Sample Too Dark	Reflectance of specimen is low.	Specimens with low reflectance cannot be measured.
Change Battery	Battery power is almost exhausted.	Replace batteries or use optional AC adapter.
Illumination Error	Lamp filament is broken or measurement circuit is malfunctioning.	If this message reappears, contact the nearest Konica Minolta Sensing authorized service facility.
Cal. Again	White calibration was performed using something other than the white calibration plate.	Use only the white calibration plate included with the Baking Meter.

CAUTION

- The Baking Meter should be used at temperatures between 0 and 40°C (32 and 104°F). Do not use the Baking Meter at temperatures outside this range. Also, do not subject the Baking Meter to sudden changes in temperature.
- Do not use the Baking Meter in an explosive atmosphere, such as one containing gasoline fumes.
- Do not leave the Baking Meter in direct sunlight or near sources of heat, such as stoves, etc. The internal temperature of the Baking Meter may become much higher than the ambient temperature in such cases.
- Do not use the Baking Meter in extremely dusty areas or in areas filled with smoke or chemical fumes.
- Do not use the Baking Meter near equipment which produces a strong magnetic field (such as speakers, large motors, etc.)
- When the Baking Meter is not in use, be sure to set the POWER switch to O (off) and cover the measurement aperture with the protective cap.
- Do not mix battery types or ages. Mixing battery types or ages could result in battery leakage, reduced battery life, or damage to the Baking Meter.
- Use only optional AC Adapter AC-A12 to supply power to the Baking Meter from an AC outlet. Use the AC Adapter AC-A12 only with the rated power source.
- Do not subject the Baking Meter to strong impact or vibration.
- If the instrument malfunctions, do not disassemble the instrument or attempt to repair it yourself. Any necessary repairs should be performed only by a authorized service facility.

CARE AND STORAGE

- To protect the white surface of the white calibration plate from changing color due to exposure to ambient light, and also to protect it from being scratched or stained, be sure to close the cover of the white calibration plate after use.
- If the Baking Meter becomes dirty, it can be cleaned by wiping with a soft, dry cloth. Do not use benzene, paint thinner, or other chemicals to clean the Baking Meter.
- If the white calibration plate becomes dirty, it can be wiped with a clean, dry cloth. If the stain is difficult to remove, a soft cloth moistened with lens-cleaning fluid may be used. After cleaning the surface with lens-cleaning fluid, wipe the surface with a cloth moistened with water and then let the surface dry before use. If the white calibration plate is scratched or has a stain which cannot be removed, it should be replaced. Contact the nearest Minolta authorized service facility to purchase a replacement.
- The Baking Meter should be stored at temperatures between -20 and 40°C (-4 and 104°F). Do not store the Baking Meter in areas subject to high temperatures, high humidity, or where condensation may occur.
- Do not leave or store the Baking Meter in direct sunlight, inside a closed motor vehicle, in the trunk of a motor vehicle, or in any other area subject to extremely high temperatures.
- Do not store the Baking Meter in extremely dusty areas or in areas filled with smoke or chemical fumes.
- If the Baking Meter will not be used for more than two weeks, remove the batteries to avoid the possibility of damage due to battery leakage or corrosion.

ACCESSORIES

Standard Accessories

Soft Case CR-A68

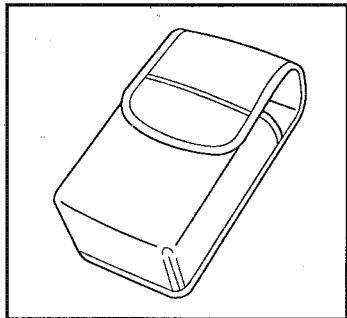

Wrist Strap CR-A73

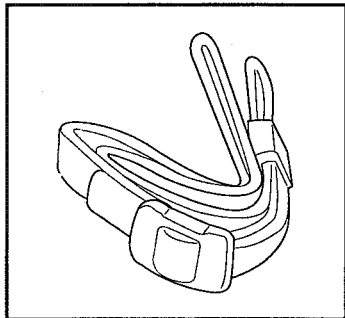

White Calibration Plate

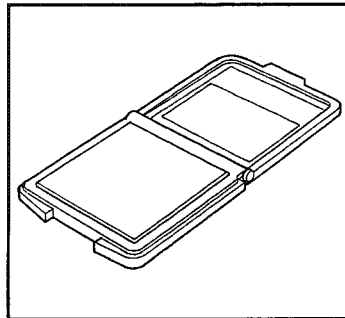

AA-size batteries (4)

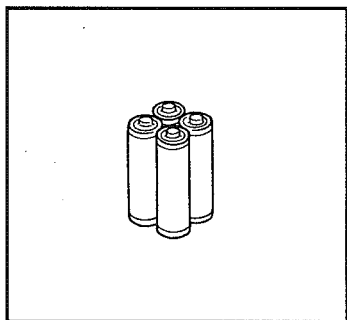

Protective Cap CR-A72

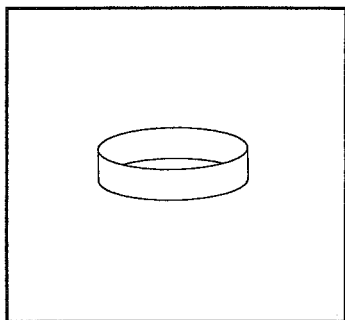

Optional Accessories

AC Adapter AC-A12

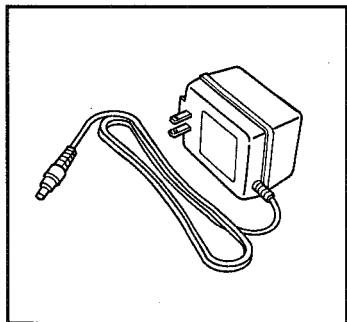

SPECIFICATIONS

Model	BC-10
Illumination/viewing geometry	8/d (8° illumination angle/diffuse viewing; specular component included)
Measuring area	Approximately ø8mm
Light source	Gas-filled tungsten lamp
Detector	6 silicon photocells
Display modes	BCU (Baking Contrast Units); L*a*b* Statistical calculation; Maximum, minimum and mean.
Minimum interval between measurements	Approx. 1 sec.
Power source	Four AA-size batteries or optional AC Adapter AC-A12
Battery life	Alkaline-manganese: Approx. 2000 measurements at 10-sec. intervals
Display	16-character x 2-row dot-matrix LCD
Operation environment	0 to 40°C (32 to 104°F); less than 85% relative humidity; Altitude: 2000m or below; Instration category: 1; Pollution degree: 2 ; Indoor use only
Storage temperature range	-20 to 40°C (-4 to 104°F)
Dimensions (W x H x D)	59 x 158 x 85mm (2-5/16 x 6-1/4 x 3-3/8 in.)
Weight	360g (12.7 oz.) not including batteries
Standard accessories	White Calibration Plate CR-A43; Soft Case CR-A68; Protective Cap CR-A72; Wrist Strap CR-A73; AA-size batteries (4)
Optional accessories	AC-Adapter AC-A12

- Specification subject to change without notice.



KONICA MINOLTA